

BLUETOOTH OPERATED SCISSOR JACK: THE FUTURE OF VEHICLE LIFTING EQUIPMENT FOR DEVELOPING COUNTRIES

Y. AboElnaga¹, H. Abuzied¹

¹Mechanical Engineering Department, Faculty of Engineering, The British University in Egypt, El Shorouk City, Cairo, Egypt

*Corresponding Author: hoda.abuzied@bue.edu.eg

Article History: Received 17 Aug 2023; Revised 29 April 2024; Accepted 16 June 2024

ABSTRACT: *The tire exchange process can be a daunting task for people with limited abilities. As the physical effort required for the conventional vehicle jack operation can be difficult or impossible for some people. Hence, manufacturers have developed electrical scissor jacks that can be controlled remotely. These jacks eliminate the need for exerting any physical effort so that people with limited abilities can change their own tires. However, commercial electrical jacks are expensive, not always available in developing countries at reasonable prices. Moreover, they are controlled using a wired remote-control device and powered by connecting alligator cables to the vehicles' battery. This paper presents the procedures needed to convert a manual commercial scissor jack to a smartphone-controlled one using developing country local market components. The jack is controlled via Bluetooth connected device and can be powered by the vehicle's cigarette lighter receptacles, alligator cables, or AC power outlet. In addition, emergency buttons are attached to the control unit in case smartphone application suddenly malfunctions during the lifting process. The prototype was successfully tested and was able to lift a vehicle 25 cm in less than two minutes. This is a significant improvement over manual jacks, which can take up to four minutes to lift the same distance. The proposed smartphone-controlled scissor jack is a valuable tool for people with limited abilities, as it makes the tire exchange process much easier and faster. The low cost and local availability of the components make it a viable option for developing countries.*

Keywords: *Automotive ergonomics; smartphone actuation; vehicle jack; musculoskeletal disorders*

1.0 INTRODUCTION

The manual tire exchange process can be considered one of the most hazardous automotive industry maintenance activities. It involves exerting a large physical effort to lift heavy objects using awkward postures that may have a negative impact on the human body. These postures can cause several musculoskeletal disorders owing to repeated or prolonged reaching, kneeling, twisting, bending, squatting, and holding fixed positions for a long period of time [1- 3]. Urging the designers and manufacturers to consider the ergonomics of the maintenance tools used, in addition to vehicle ergonomics [4]. Scissor jacks are one of the most commonly used tools for tire exchange/repair, either in vehicle service centers or by vehicle owners. Their operation

depends on the physical effort exerted by the user, which may cause musculoskeletal disorders [5], [6].

Several researchers have investigated the development of commercial manual scissor jacks by introducing electric motors to replace manual operation. The necessary power for the electric motor's operation can be supplied by connecting alligator cables directly to the vehicle battery or use external rechargeable batteries. The upward and downward movements of the jack are controlled using switch buttons to reverse the direction of motor rotation [1], [7-10]. Furthermore, alligator cables were replaced by a lighter cigarette receptacle. Thus, the necessary power for operation can be supplied directly from the vehicle's cabin, eliminating the need to open the hood [3], [11-14]. The urging demands in considering the ergonomics of the vehicle's maintenance tools have encouraged further developments to enhance user energy saving and comfort needs [4]. This was achieved by replacing the switch buttons used to control motor movement with a wired remote-control device [10], [14 -19]. In addition, wireless communication technology has been introduced to replace the wired remote-control devices. The wireless connection was established by connecting the jack's motor to a smartphone device via an Arduino system or microcontroller and a Bluetooth module to lift a load of 4.5 kN. This control technique is characterized by its ease of use and compact size. This is because it requires only a smartphone user eliminating any need to make dangerous physical movements to control the movement of the jack. In addition, wireless communication reduces the number of wires needed to control the jack's movement. As, wires will be used only to supply the used motor with the necessary power, while its motion and speed can be controlled through smart phones [1], [2], [10].

To the author's knowledge, commercial electrical scissor jacks available in the developing countries domestic market are controlled using a wired remote-control device and powered by connecting alligator cables to the vehicles' battery. In addition, they are expensive and are not available at a reasonable cost in the domestic market. This paper discusses the procedures for converting a 1-ton manual commercial scissor jack into a smartphone-controlled one via Bluetooth connected devices and local market components available in developing countries. The necessary power for operation can be supplied using any of the available power outlets in the vehicle, including the vehicle battery through alligator cables, the lighter cigarette receptacle, or the AC power outlets available in some vehicles. This allows the jack to be operated with or without the need to open the vehicle's hood. The presented prototype is characterized by its low cost, feasibility, safe operation, and compact size. The use of smartphones as a controlling device eliminates the need for physical effort during jack operation and reduces the number of control wires needed. In addition, it allows the free movement of the user within the Bluetooth range. The emergency buttons attached to the control unit allow the completion of the lifting process if any sudden malfunction occurs to the used smartphone.

2.0 DESIGN PROCEDURES

This section discusses the procedures of converting a 1-ton commercial scissor jack to a more user friendly one. This process was done in two phases. The first phase will discuss the necessary modification to be made on the commercial scissor jack to replace its manual operation with a remotely controlled DC motor. The second phase will discuss the control system used to manage the lifting process of the scissor jack during its operation using smart phone.

2.1 Mechanical design

The proposed modifications were made on a commercial scissor jack with a load carrying capacity of 1 ton. The manual operation of the jack was replaced by a remotely controlled DC motor. This was done by connecting the power screw to the DC motor using coupling box as shown in Figure 1A. To enhance the stability of the jack and the attached motor during the lifting process, the whole mechanism was placed on a 20x80 mm Aluminum extrusion base plate. The base plate was formed to have V-slots to ensure the smooth movement of the motor during the lifting process. To minimize the vibrations of the motor during the vertical movement of the jack, a slider mechanism is used, and the motor housing is connected to the base using one connecting link as depicted in Figure 1A and B. The slider guide ways of the sliding mechanism are attached to the motor housing and one end of the jack while the sliding roller is attached to the other end of the jack as shown in Figure 1B. So that the horizontal alignment of the motor can be maintained, and the vibration generated during the vertical movement can be suppressed. The vertical upward and downward distance traveled by the jack is controlled by the sliding action to position limit switches as shown in Figures 1A. The necessary power for operation is supplied by connecting the plug shown in Figure 1 directly to either AC power outlet available in the vehicle or vehicle's battery using alligator cables or cigarette lighter receptacle.

The used motor is one of the main parameters that governs the successful operation of the lifting process. It must provide output torque higher than that needed to lift the vehicle. The torque (T) required to be provided for the lifting process was calculated using Eq.1 [20] then validated using Solidworks motion analysis.

$$T = P \cdot dm \cdot \tan(\phi + \alpha) + \mu \cdot dc \cdot P \quad \text{Eq.1}$$

Where:

P	: maximum applied load	10000 N
dm	: mean diameter of power screw	11 mm
dc	: collar diameter	5 mm
Φ	: friction angle [20]	15°
α	: helix angle [20]	10°
μ	: Coefficient of friction	0.2

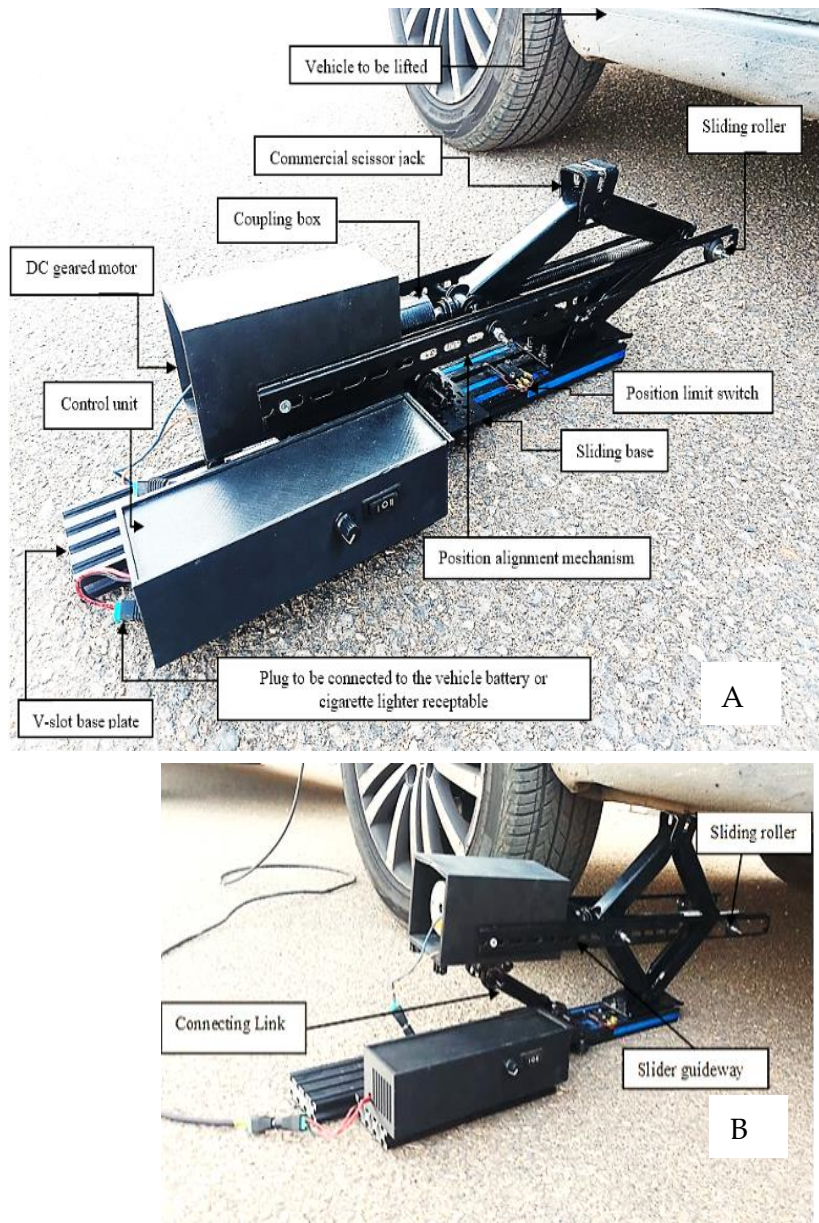

Figure 1: A&B shows the different components used in the modified Scissor jack during its testing

2.2 Solidwork simulation

Solidwork motion analysis case study was conducted to estimate the motor power needed to complete the lifting process. In addition, validating the magnitude of the torque estimated using the classical design equation described in section A. The Motion analysis was run against a load of 1 ton assuming a motor speed of 25 rpm. It was found that the jack can lift the vehicle up to 25 cm in 40 seconds using a power of 17 watts. It was found that the magnitude of the maximum torque needed is consistent with that obtained using the classical design equation in section A. Figures 2,3 & 4 show the magnitude of needed motor torque and power, and the vertical lifting distance in 40 seconds.

2.3 Control system

Arduino Nano was used to control the scissor jack movement using a smartphone Bluetooth connection. The power necessary for the motor operation is supplied by connecting the DC motor to the vehicle AC power outlet or battery. The connection to the AC power outlet is made using AC-DC adaptor to convert 220 V AC to 12 V DC. The connection to the battery is made using alligator cables and cigarette lighter receptacle, respectively.

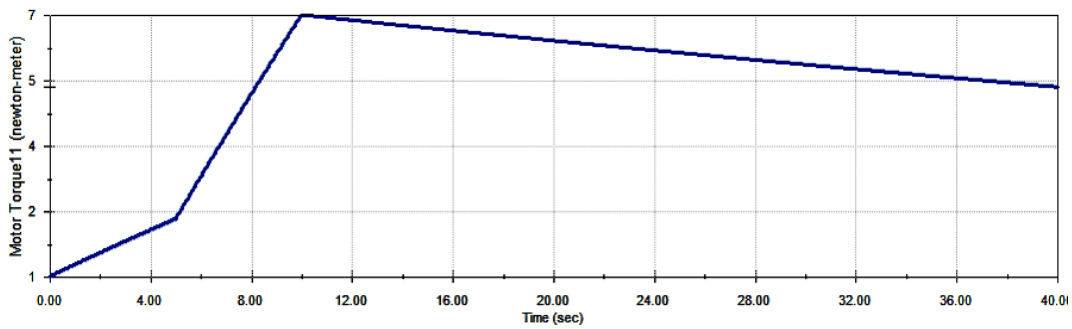

Figure 2: Motor torque vs Time

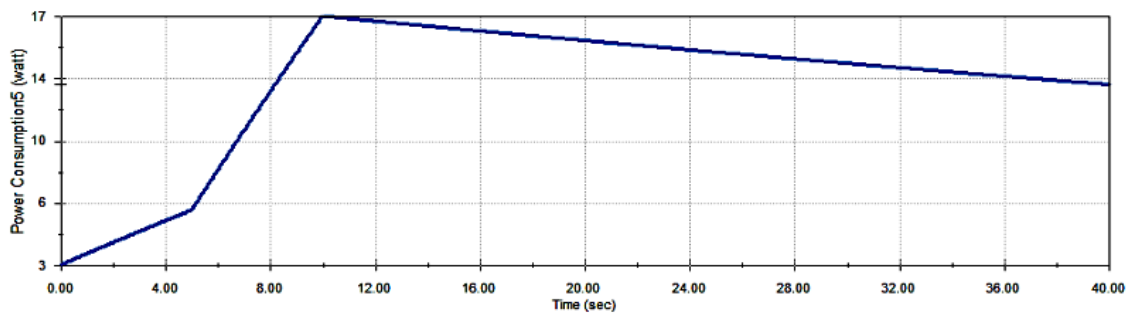

Figure 3: Motor power vs Time

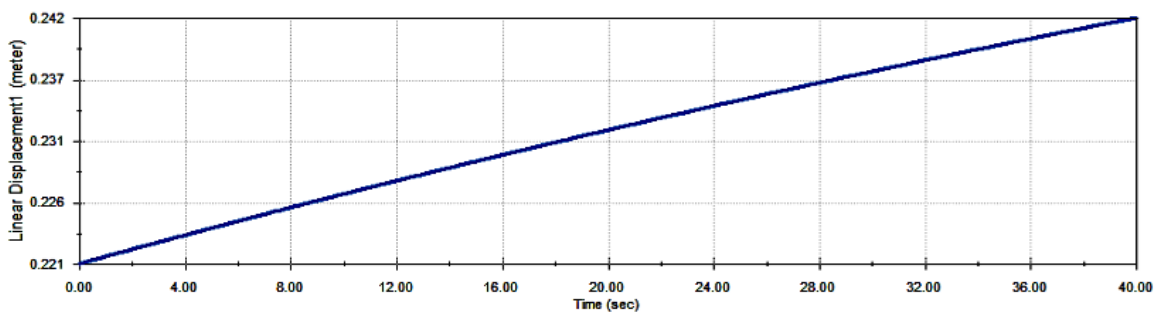

Figure 4: Lifting distance vs Time

A step-up DC-DC converter is used to step up the battery's output voltage from 12 V to 24 V to be suitable for the 24 V DC motor. A DC-DC step down converter is used to convert the 24V supplied from the step-up converter to the required 5V needed for the Arduino board which controls the whole system as shown in Figure5. A smartphone android application (Bluetooth Electronics) is used to control the jack's movement by transmitting signals to the HC-05 Bluetooth module. The Arduino receives a signal from the HC-05 Bluetooth

module to control the jack’s motion. MD10- POT motor driver board is used to control the motor speed besides allowing its rotation in both directions.

Switch buttons and potentiometer are attached to the housing of the control unit as emergency buttons. So that the control process can be completed if any sudden damage occurs to the used smart phone. Figures 6 and 7 show a flow chart for the developed jack control process and the developed interface for the used smart phone application, respectively.

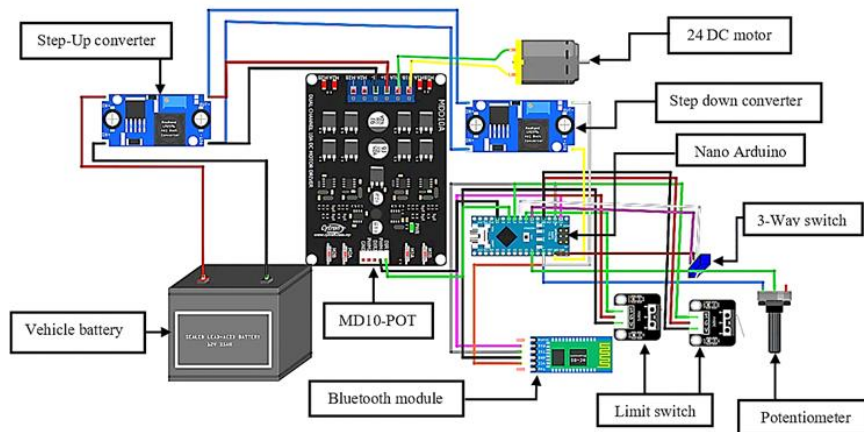

Figure 5. Details of the used control circuit

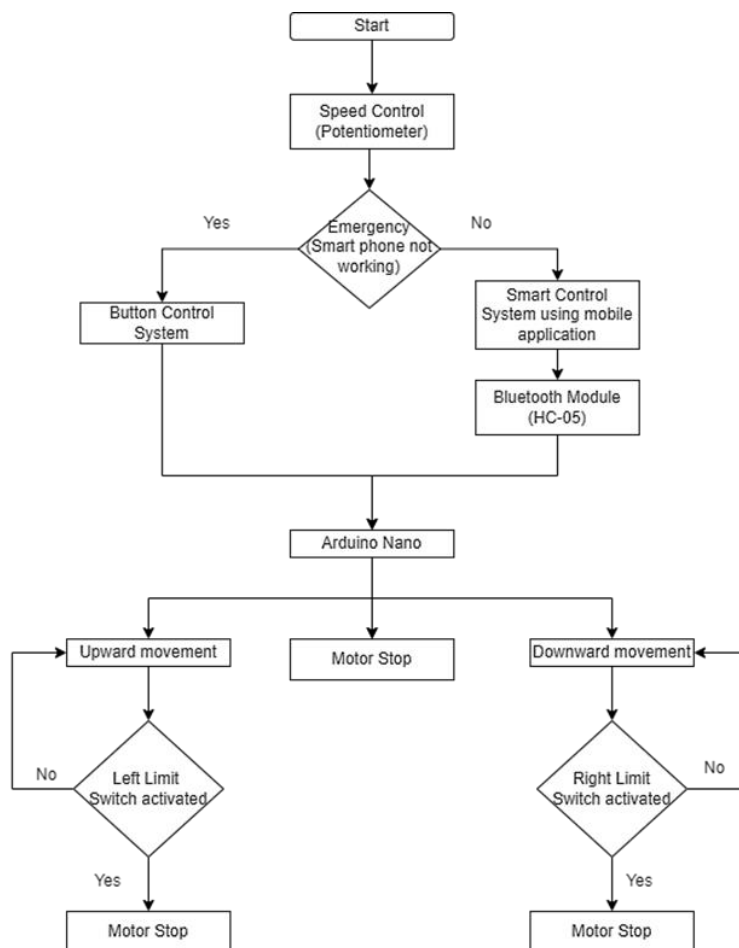

Figure 6: A flow chart for Jack control

3.0 EXPERIMENTAL TESTING

This section describes the experimental procedures conducted to test the developed prototype after implementing the suggested modifications. The testing process was conducted in four stages. The first stage was running a manual test using the conventional jack before implementing the suggested modifications. This test was needed to estimate the time taken to complete the manual lifting process by a mid-aged young user. The second stage involves testing the developed jack powered by direct connection of the plug to the vehicle's battery using alligator cables. The third stage involves testing the developed jack powered by connecting the plug to the vehicle's cigarette lighter receptacle as shown in Figure 8. The fourth stage involves testing the developed modified jack powered by connecting the motor plug to the vehicle AC power outlet. These tests were conducted to investigate whether the jack can be operated using different modes of operation. Also, estimate whether the different modes of operation have an effect on the duration of the lifting process.

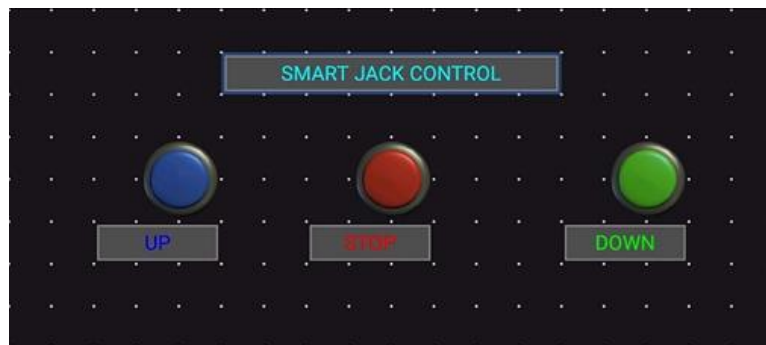

Figure 7: Developed Smart phone application



Figure 8: Modified jack connected to the vehicle battery using cigarette lighter receptable.

4.0 DISCUSSION OF RESULTS

The first stage of testing covered the manual operation of the jack to estimate the time needed to lift the vehicle 25 cm. This test was conducted Eight successive times to measure the effect of human fatigue in case the user can exert a limited effort. It was found that four minutes were needed at the beginning of the testing cycle to lift the required distance. Then, kept increasing upon increasing the number of trials due to the human fatigue.

The second stage of testing investigated the effect of replacing the manual operation with a smart phone controlled one. The necessary operation power was supplied by direct connection to the vehicle's battery using alligator cable. It was found that the same distance traveled using manual operation was covered in less than two minutes. This achievement represents a great improvement as the modified jack successfully lifted the vehicle in a time span less than that needed using manual operation by about 50 %. Upon repeating the experiment, the estimated time has not changed.

The third stage of testing investigated the effect of changing the means of connection to the vehicle battery. The necessary operation power was supplied using cigarette lighter receptible instead of direct connection using alligator cables. Upon testing, the lifting process was completed at the same time estimated using alligator cables. The fourth stage of testing investigated the effect of replacing the vehicle's battery with the vehicle's AC power outlet. The same result obtained during the second and third phase of testing was also achieved. Hence, the needed power can be supplied using all available power outlets in the vehicle without having a significant effect on the lifting process in terms of time. Further, the necessary power can be supplied directly from the vehicle's cabin without any need to open the hood.

5.0 CONCLUSION

The present paper successfully converted a 1-ton commercial manual scissor jack to an electrical one controlled by a smartphone application. The proposed modifications enhanced the lifting process by reducing the lifting time by 50%. The developed jack is characterized by its safer use compared to manual jacks, as there is no risk of the user being injured by the jack. It is also more convenient and versatile, as the user does not have to open the hood of the vehicle to reach the power source and can be powered by a variety of sources, including the vehicle's cigarette lighter, alligator cables, or the AC power outlets available in some vehicles.

In addition, the use of only local components enhanced its availability in the domestic market of developing countries at a reasonable cost. Moreover, the existence of emergency buttons allows completing the lifting process smoothly in case any sudden malfunction occurs to the used smartphone. Therefore, the proposed smartphone-

controlled scissor jack is a valuable tool that can make the tire exchange process easier, safer, and more convenient for people with limited abilities.

REFERENCES

- [1] M. P. Ashif, M. M. Thabseer, and M. Ashif, "Design and Fabrication of IOT based Motorized Screw Jack," *International Research Journal of Modernization in Engineering Technology and Science*, vol. 3, no. 06, pp. 1368–1373, 2021.
- [2] K. J. M. N. K. Abhinash, N. Sandeep, S. Rahul, G. Naveen and ., "Design and Fabrication of Mobile Control Screw Jack," *International Journal & Magazine of Engineering, Technology, Management and Research*, vol. 8, no. 8, pp. 8–18, 2021.
- [3] I. Madanhire, T. Chatindo, and C. Mbohwa, "Development of a Portable Motorized Car Jack," in *Proceedings of the International Conference on Industrial Engineering and Operations Management*, Pilsen, Czech Republic, 2019, pp. 1746–1753.
- [4] V. D. Bhise, *Ergonomics in the automotive design process*, no. 12. CRC Press, Taylor & Francis Group, 2016.
- [5] G. Shashikant Udgirkar, M. Shantinath Patil, R. Vijay Patil, N. Ramchandra Chavan, and M. Panchbhai, "Design, Development and analysis of electrically operated toggle jack using power of car battery," 2014.
- [6] T. Ajay, G. D. Jacob, A. Shameer, and D. Ramalingam, "Design and Fabrication of Devising Simplified Motorized Scissor Jack," *International Journal of Management, Technology and Engineering*, vol. 8, no. 2007, pp. 2007–2014, 2018.
- [7] C. Emmanuel Chinwuko et al., "Design and Construction of a Powered Toggle Jack System," *American Journal of Mechanical Engineering and Automation*, vol. 1, no. 6, pp. 66–71, 2014.
- [8] KamalakkannanA, KalaiselvanP, IsaacR, and VijayV, "Automatic Motorized Scerw Jack to Redused Manpower," *Int J Sci Eng Res*, vol. 7, no. 5, pp. 21–24, 2016.
- [9] R. Kumar, S. Choudhary, D. Pasbola, and S. Dabral, "Development of Motorized Car Jack," *International Journal of Research*, vol. 3, no. 8, pp. 324–330, 2016.
- [10] M. P. Chitins, M. M. Gudasalamani, M. P. Paradesi, M. P. Jatti, M. Shrinivas, and A. Professor, "Design and Fabrication of Automated Scissor Jack," *International Journal of Engineering Research & Technology*, vol. 8, no. 11, pp. 849–851, 2019.
- [11] D. R. More, A. A. Patil, A. A. Thakare, N. R. Vartak, and M. S. Ansari, "Design and Fabrication of Motorized Hydraulic Jack System," *Int J Res Appl Sci Eng Technol*, vol. 10, no. 4, pp. 1060–1065, 2021.

- [12] B. V Krishnaiah, H. Basha, M. Lokesh, Afridee, and V. Krishna, "Design and Fabrication of Motorized Scissor Jack," *Dogo Rangsang Research Journal*, vol. 8, no. 14, pp. 464–469, 2021.
- [13] H. Oberoi and R. Shrivastwa, "Design and fabrication of remote operated scissor jack," *International Research and Development Journal in Engineering & Science*, vol. 1, no. 1, 2022.
- [14] M. Yousuf, S. Ashraf, and Y. S. Iqbal, "Motorized Screw Jack," *International Journal of Science and Research*, vol. 6, no. 5, pp. 2319–7064, 2015.
- [15] P. S. Rana1, "Integrated Automated Scissor Jack for LMVs," *International Journal of Engineering Research & Technology*, vol. 2, no. 4, pp. 1518–1527, 2013.
- [16] O. T. Egwerome Oghenekome and O. Patrick, "Design and Implementation of a Remote-Controlled Car Jack," *Journal of Advancement in Engineering and Technology*, vol. 1, no. 1, pp. 1–7, 2014.
- [17] M. S. Kothalkar and M. K. Bhange, "Design & Development of Automatic Lifting System in Automobile," *International Journal of Engineering and Techniques*, vol. 4, no. 2, pp. 913–917, 2018.
- [18] B. Singh and A. K. Mishra, "Analysis and Fabrication of Remote-Control Lifting Jack," *International Journal of Scientific Engineering and Applied Science (IJSEAS)*, vol. 1, no. 3, pp. 308–319, 2015.
- [19] V. Pradeepa, P. Kumar, S. K. K, N. N. C, and R. Jadar, "Design and Fabrication of Remote-Controlled Hydraulic Jack," *International Research Journal of Engineering and Technology*, vol. 6, no. 5, pp. 1765–1769, 2019.
- [20] Richard G. Budynaslia and J. Keith Nisbett, *Shigley's Mechanical Engineering Design*, vol. 9th edition. 2011.